

Weigh-In-Motion Axle Scale

Fast, Accurate Axle & Gross Weighing
for all Vehicle Types



In-Ground, Weigh-In-Motion Scale Offers Superior Accuracy for High-Volume Vehicle Weighing

Intercomp's LS-WIM scale system is a cost-effective, intuitive, weigh-in-motion solution for your operation. Accurately and efficiently know where every load originated, was delivered, what commodity, the moisture percentage and who hauled it. An Intercomp LS-WIM scale solution is a key component to keeping your harvest running smoothly, ensuring trucks maximize time hauling grain, and keeping your combine running in the field.

Weigh-In-Motion Axle Scales

Monitor Yields | Maximize Loads | Verify Loads for Security

Intercomp's Weigh-In-Motion Scale System

LS-WIM In-Ground Weigh-In-Motion Scale Systems are an ideal alternative to older static truck scales that require drivers to stop on the scales to manually receive a weight. Intercomp's LS-WIM scales will increase overall efficiency, are far more economical and will even provide individual axle weights along with total gross weights. The small footprint of these scales allow them to be installed in a matter of days, keeping downtime to a minimum, and are also far less expensive to purchase and install than traditional truck scales.

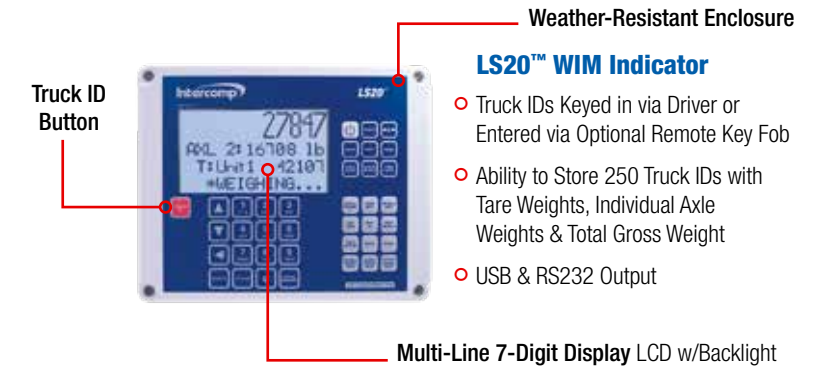
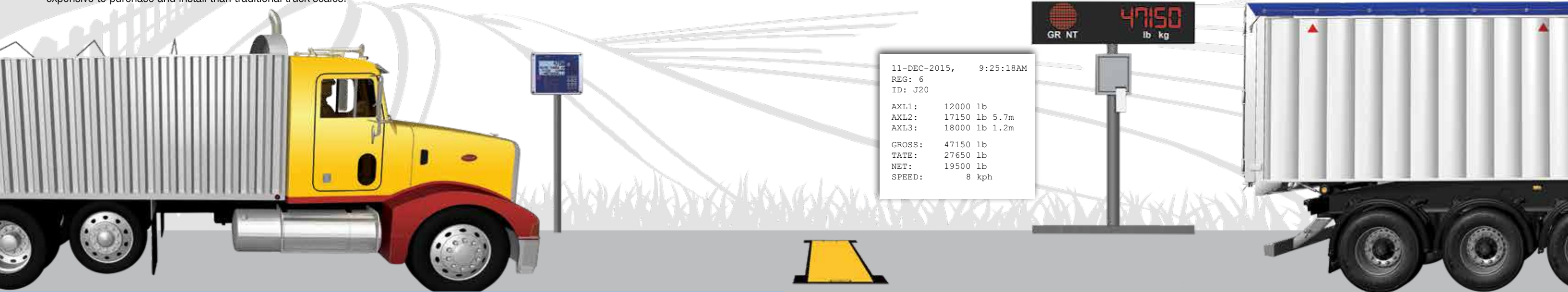

LS-WIM SCALE

- NTEP/OIML Certified Load Cells
- Small Footprint for Ease of Installation
- Removable Platform for Service & Maintenance
- Overall Depth just 12.5" (318 mm)
- NTEP Certified in Static Mode



LS20™ WIM INDICATOR

- Data Storage Capacity of 1,500 Weigh Records, 36 Axles Per Record
- Data Recall- All Stored Records can be Recalled to View or Print
- Data Export- All Records can be Exported via USB or RS232
- Tamper-Proof Adhesive Seal across Enclosure Lid Seam
- Weather Resistant USB & RS232 Serial Output



STANDARD LED SCORE BOARD

- 6-Digit, 4.5" (115 mm) Alpha/Numeric LED Display
- Lightweight & Easy to Mount
- 5" (127 mm) Stop & Go light
- Displays in lb or kg
- Weather-Proof Enclosure



OPTIONAL KEY FOB

- Allows Drivers to Activate the System Remotely
- Transmits the Vehicle's Unique I.D.

Weigh-In-Motion Axle Scale

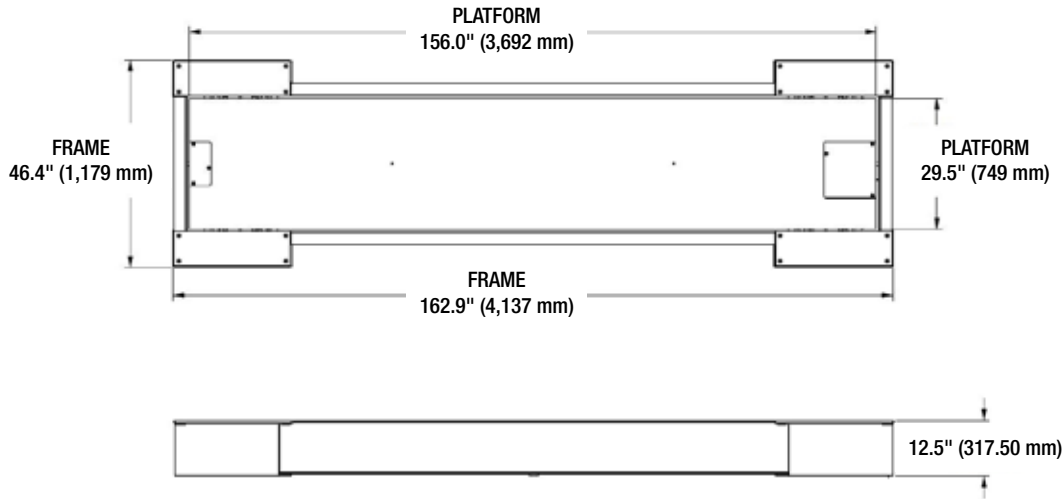

LS-WIM Scale Specifications

Capacity	45,000 lb (20,000 kg)
Dimensions	162.9 in x 46.4 in (4,137 mm x 1,179 mm)
Deck Thickness	12.5 in (317.5 mm)
Vehicle Speed Range	0 mph to 20 mph (0 km/hr to 35 km/hr)
Operating Temperature Range	-29° to 165°F (-34° to 74°C)
Power	110/220V 50/60 Hz
Cable Type	6 Conductor Cable with Shield, ± Excitation, ± Signal, ± Sense
Cable Length	100 ft (30 m) — Custom Lengths Available per Customer Request
Recommended Excitation	5-10V
IP Rating	IP68

*Higher Capacities are Available

Accuracy

Static Accuracy	±0.1% of Applied Load
Dynamic Accuracy	1-2% at Low Speeds**

**Site Conditions & Vehicle Speeds Can Affect GVW Accuracy

LS20™ WIM Indicator Specifications

Electrical

Operating Temperature Range	-4° to 140°F (-20° to 60°C)
Power	100 to 240 VAC, 50 to 60 Hz. 2.5W typical

Environmental

Hardened Case Rated IP65
Humidity 10 to 95% Non-Condensing

info@intercompcompany.com
Worldwide: +1 763-476-2531
Toll Free: 800-328-3336

© 2019 Intercomp Company



Specifications subject to change without notice.

CE ISO 9001:2015
Registered



Printed in the U.S.A.

700787