

# CSP™ Portable Test Stand

## Factory Certified Scale Calibration



### ***Easily & Efficiently Assess Product Performance with this Portable Test Stand***

Optimized for mobility, the CSP™ Portable Test Stand is ideal for locations with limited space or for bringing to job sites or locations where a large number of scales are stored. The size provides users with an economical and flexible solution that is easily transported using integrated forklift pockets and can be set up on any flat, level surface, such as a floor or truck bed.

With a capacity of 30,000 lb (13,600 kg) and a test platform area of 31 x 48 inches (787 x 1219 mm), the press is capable of calibrating a wide range of Intercomp's single and dual-tire portable wheel load scales. The rigid steel frame and test platform combined with the precision load cell and indicator ensure all testing is completed to the most exacting specifications.

## PORTABLE TEST STAND

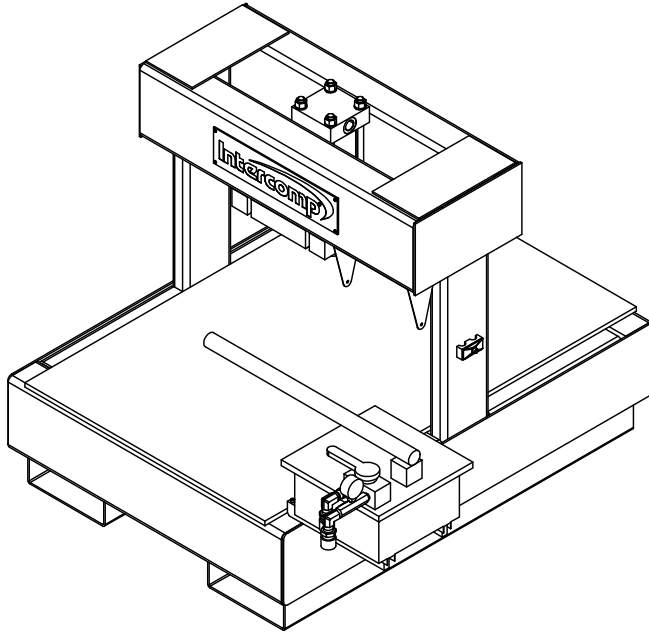

- 30,000 lb (13,600 kg) Capacity
- Accuracy of  $\pm 0.25\%$  of Reading
- Factory Certified Load Cell
- High Speed Hand Pump Uses Standard Hydraulic Fluid & Features 2 Speeds
- Active Measurement Area: 31" x 48" (787 x 1219 mm)
- Integrated Forklift Pockets for Ease of Transportation

### CSP™ Specifications

Capacity	Up to 30,000 lb (13,600 kg)
Accuracy	$\pm 0.25\%$ of Reading
Stability	0.001% of Load Cell Capacity
Resolution	Adjustable Down to 0.001% of Load Cell Capacity
Power Source	110/240 AC Single Phase
Test Measurement Area	31 x 48 in (787 x 1219 mm)
Overall Size	47.37 x 52.32 x 40.06 in (1203.15 x 1328.85 x 1017.40 mm)

## Calibration & Maintenance Services

Our headquarters in Medina, Minnesota- USA offers a full service center and certified technicians providing complete repair, support and calibration for all Intercomp products. Featuring high-precision, fully automated force calibration systems with capacities to 50 tons and tension calibration systems with capacities to 250 tons, we calibrate scales & systems with standards traceable to U.S. National Institute of Standards and Technologies (NIST). Intercomp also maintains an inventory of over 20,000 pounds in dead weights used for testing and calibration which are certified by the MN Department of Weights & Measures.

For customers located in Europe, Middle East and Africa, Intercomp has a sales and service center in the United Kingdom as well. Calibration capabilities include dead weight and fully automated forces of up to 50 tons with standards traceable to the Bureau International des Poids et Mesures (BIPM).

Both calibration and repair facilities are regularly audited as part of our ISO 9001:2015 Certification.

[info@intercompcompany.com](mailto:info@intercompcompany.com)  
Worldwide: +1 763-476-2531  
Toll Free: 800-328-3336

© 2022 Intercomp Company



Specifications subject to change without notice.



Printed in the U.S.A.

7005209