

CS750™ Hanging Scales

Medium-Duty Digital Hanging Scale for Industrial Applications



Durable Hanging Scale Offers Comprehensive Industry Features & Superior Battery Life

Available in capacities ranging from 100 lb (50 kg) to 1,000 lb (500kg), including NTEP certified models, the durable CS750™ Crane Scale boasts an impressive 800 hours of continuous battery life (5,000 hours in stand-by mode), minimizing down time due to battery charging or replacement. The unit can be ordered with or without Fully Integrated RFX® Wireless Weighing Technology and comes standard with an infrared remote control, Crosby eye hook and bottom swivel hook.

The large LCD display with automatic backlight provides easy-to-read weight readings, and a comprehensive set of keypad controls, including Tare and Accum/Total, make CS750™ Crane Scales the go-to solution for light industrial applications. All crane unit electronics are shock-mounted in a weatherproof case and provide maximum protection against moisture, dust and rough usage.

CS750™ HANGING SCALES



IP50 Protection

Accuracy of ±0.1% of Reading

Available in Capacities
Up to 1,000 lb (500 kg)

Large, Easy-to-Read, LCD Display

Commercially-Available D-Cell Batteries
Last up to 800 Hours

Features Backlight, On/Off, Peak/Hold
Function & Zero

Includes:

- Alkaline Batteries
- Top Eye Hook
- Bottom Swivel Hook
- Infrared Remote Control w/
Batteries



Upper Eyelet Opening*:
W: 1.25" (32 mm)
H: 1.44" (36.5 mm)

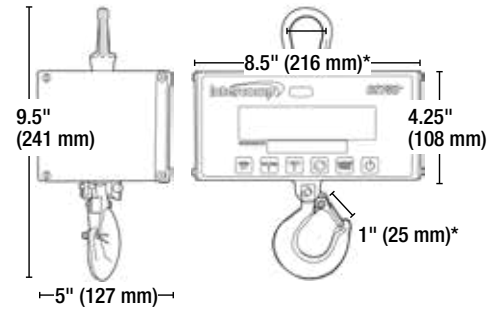

*Specs are based on industry-standards,
please call if your application has precise
measurement requirements.



NTEP Certified Models Available



PART #	DESCRIPTION	CAPACITY/GRADUATION	SHIPPING WEIGHT
184252	CS750 HANGING SCALE (100 X .05)	100 X .05 LB (50 X .02 KG)	8 LB (4 KG)
184253	CS750 HANGING SCALE (300 X .1)	NTEP CLASS III/IIIL 300 X .1 LB (150 X .05 KG)	8 LB (4 KG)
184254	CS750 HANGING SCALE (500 X .2)	NTEP CLASS III/IIIL 500 X .2 LB (250 X .1 KG)	8 LB (4 KG)
184255	CS750 HANGING SCALE (1K X .5)	NTEP CLASS III/IIIL 1,000 X .5 LB (500 X .2 KG)	8 LB (4 KG)

NTEP 97-135A4

CS750 Accessories

PART #	DESCRIPTION	SHIPPING WEIGHT
101231	CABLE, CS750/CS1500/CS3000 TO THERMAL PRINTER (15'/4.5 M). OPTION 184507 REQUIRED	2 LB (1 KG)
101233	CABLE, SERIAL OUTPUT CS750/CS1500/CS3000 TO RS232/USB (15'/4.5 M). OPTION 184507 REQUIRED	2 LB (1 KG)
184507	RS232/DIRECT POWER CONNECTOR FOR CS1500/CS3000 (MUST BE ORDERED W/SCALE)	2 LB (1 KG)
184257	ADD RFX WIRELESS TO CS750	
184256	CS750 RS232 SERIAL OUTPUT & DIRECT POWER CONNECT (MUST BE ORDERED W/SCALE) - CABLE NOT INCLUDED	
750501	CERTIFICATE OF CALIBRATION	

info@intercompcompany.com
Worldwide: +1 763-476-2531
Toll Free: 800-328-3336

© 2020 Intercomp Company



Specifications subject to change without notice.

CE ISO 9001:2015
Registered



Printed in the U.S.A.

700728